

# HS24 HS120

## Horn/Strobe Assembly



The HS24 and HS120 outdoor Horn/Strobe Assemblies are high performance, high intensity appliances. They feature prominent visibility, distinguished reliability and long operating life.

**T**he HS24 and HS120 Horn/Strobe assemblies, when installed with the weather proof mounting box, provide an audible and visual alarm indication in the harshest of environments. The horn provides a selectable continuous tone or temporal patterns. The strobe light is UL 1638 Approved for visual signaling appliances private mode and emergency and general utility signaling for use in outdoor applications.

### Specifications

**Strobe Intensity:**  
75 Candela

**Flash Rate:**  
60 per minute

**Sound Output:**  
75 dB / 10 ft.

**Supply Voltage:**  
HS24 – 24 VDC  
HS120 – 120 VAC

**Wires:**  
Gauge:  
#18 AWG

Horn Color:  
2 - Orange (+)  
2 - White (-)

Strobe Color:  
2 - Red (+)  
2 - Black (-)

Specifications subject to change without notice.

### Dimensions

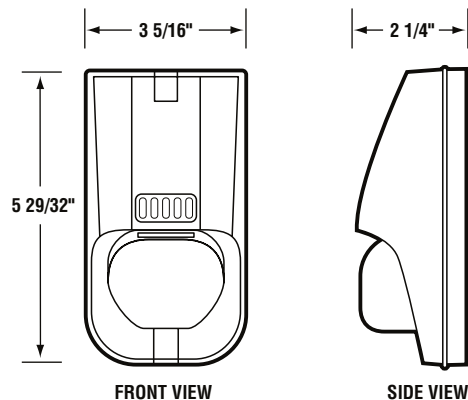

### Key Features

Designed to meet or exceed NFPA/ANSI Standards and ADA Accessibility Guidelines

Weather proof, wall mount design

Separate horn and strobe circuits

Strobe flashes at 1 flash per second

75 candela intensity

75 dB/10 ft. sound output level

Low current draw

Concealed mounting screw

Mounts to weather-proof back box

Blue strobe lens cover

Sold per Manning Systems standard Limited Warranty.



11511 West 83rd Terrace  
Lenexa, Kansas 66214  
1.800.444.9935 or 913.894.1185  
fax 913.894.1296

email [sales@manningssystem.com](mailto:sales@manningssystem.com)  
[www.gasalarm.com](http://www.gasalarm.com)

Manning Systems, Inc. provides a complete line of industrial quality Gas Alarm Monitoring Systems for equipment rooms, refrigerated spaces, storage facilities, laboratories and process areas.

---

**BW Technologies**

1-888-749-8878	USA
1-800-663-4164	Canada
+44 (0) 1869 233004	Europe
+971-4-8871766	Middle East
+61-7-3818-8244	Australia
+852-2974-1783	China
+1-403-248-9226	Other Countries

**Corporate Headquarters**

2840-2 Avenue S.E.  
Calgary, AB, Canada T2A 7X9  
Phone: +1-403-248-9226  
Fax: +1-403-273-3708

E-mail: [info@bwt.net](mailto:info@bwt.net)

**[www.gasmonitors.com](http://www.gasmonitors.com)**