

GasAlert Extreme

O₂, CO, H₂S, PH₃, SO₂, Cl₂, NH₃, NO₂, HCN, ETO, ClO₂, O₃, or NO

Single Gas Detector

User Manual

"INNOVATORS IN GAS DETECTION"

BW
Technologies

Limited Warranty & Limitation of Liability

BW Technologies Ltd. (BW) warrants this product to be free from defects in material and workmanship under normal use and service for a period of two years, beginning on the date of shipment to the buyer. This warranty extends only to the sale of new and unused products to the original buyer. BW's warranty obligation is limited, at BW's option, to refund of the purchase price, repair, or replacement of a defective product that is returned to a BW authorized service center within the warranty period. In no event shall BW's liability hereunder exceed the purchase price actually paid by the buyer for the Product.

This warranty does not include:

- a) fuses, disposable batteries or the routine replacement of parts due to the normal wear and tear of the product arising from use;
- b) any product which in BW's opinion, has been misused, altered, neglected or damaged by accident or abnormal conditions of operation, handling or use;
- c) any damage or defects attributable to repair of the product by any person other than an authorized dealer, or the installation of unapproved parts on the product; or

The obligations set forth in this warranty are conditional on:

- a) proper storage, installation, calibration, use, maintenance and compliance with the product manual instructions and any other applicable recommendations of BW;
- b) the buyer promptly notifying BW of any defect and, if required, promptly making the product available for correction. No goods shall be returned to BW until receipt by the buyer of shipping instructions from BW; and
- c) the right of BW to require that the buyer provide proof of purchase such as the original invoice, bill of sale or packing slip to establish that the product is within the warranty period.

THE BUYER AGREES THAT THIS WARRANTY IS THE BUYER'S SOLE AND EXCLUSIVE REMEDY AND IS IN LIEU OF ALL OTHER WARRANTIES, EXPRESS OR IMPLIED, INCLUDING BUT NOT LIMITED TO ANY IMPLIED WARRANTY OF MERCHANTABILITY OR FITNESS FOR A PARTICULAR PURPOSE. BW SHALL NOT BE LIABLE FOR ANY SPECIAL, INDIRECT, INCIDENTAL OR CONSEQUENTIAL DAMAGES OR LOSSES, INCLUDING LOSS OF DATA, WHETHER ARISING FROM BREACH OF WARRANTY OR BASED ON CONTRACT, TORT OR RELIANCE OR ANY OTHER THEORY.

Since some countries or states do not allow limitation of the term of an implied warranty, or exclusion or limitation of incidental or consequential damages, the limitations and exclusions of this warranty may not apply to every buyer. If any provision of this warranty is held invalid or unenforceable by a court of competent jurisdiction, such holding will not affect the validity or enforceability of any other provision.

BW Technologies Ltd.
2840 – 2nd Ave. SE
Calgary, AB T2A 7X9
Canada

BW Technologies Inc. (America)
3279 West Pioneer Parkway
Arlington, TX 76013
USA

BW Europe Ltd.
101 Heyford Park,
Upper Heyford, Oxfordshire OX25 5HA
United Kingdom

Table of Contents

Title	Page
Introduction	1
Contacting BW Technologies	2
Safety Information - Read First.....	2
Getting Started.....	5
Activating the Detector	9
Self-Test	9
Self-Test Pass	11
Self-Test Fail	11
Deactivating the Detector	12
Confidence Beep	12
User Options Menu.....	13
Exit Option	14
Date and Time Option	14
Pass Code Protection Option	15
Stealth Mode Option.....	16
Automatic Backlight Option	16
Latching Alarm Option.....	17
Automatic Oxygen Calibration Option	17
Calibration Past Protection Option	18
Languages Option	18

Title	Page
Datalogger Sampling Rate Option.....	18
Data Transfer Option	19
Datalog and Event Log	20
Datalog	20
Event Log.....	21
Alarms.....	22
Computed Gas Exposures	24
Viewing Gas Exposures	25
Gas Alarm Setpoints.....	26
Resetting Gas Alarm Setpoints	26
Stopping a Gas Alarm	27
Sensor Alarm.....	27
Low Battery Alarm	28
Automatic Shutdown Alarm	28
Calibration and Setting Alarm Setpoints.....	29
Guidelines.....	29
Test Cap	30
Calibration Procedure.....	31
Maintenance	39
Cleaning a Sensor Screen	39
Cleaning a Sensor	39
Clearing a Sensor.....	39
Replacing the Battery or Sensor.....	40
Troubleshooting	42
Replacement Parts and Accessories	45
Specifications.....	46
General Specifications for Datalogger Units	47

List of Tables

Table	Title	Page
	GasAlert Extreme Order Number.....	ii
1.	GasAlert Extreme Models	1
2.	International Symbols	4
3.	GasAlert Extreme Detector	6
4.	Display Elements	7
5.	Pushbuttons	8
6.	Alarms	22
7.	Computed Gas Exposures.....	24
8.	Gas Alarm Setpoints	26
9.	Factory Alarm Setpoints.....	26
10.	Test Cap.....	30
11.	Replacing the Battery or Sensor	41
12.	Troubleshooting Tips	42
13.	Replacement Parts and Accessories	45

List of Figures

Figure	Title	Page
1.	GasAlert Extreme Detector	6
2.	Display Elements	7
3.	Test Cap.....	30
4.	Replacing the Battery or Sensor	41

GasAlert Extreme

User Manual

Order Number	Description
GAXT-X	GasAlert Extreme O ₂
GAXT-M2	GasAlert Extreme CO (low H ₂ sensitivity)
GAXT-M	GasAlert Extreme CO
GAXT-H2	GasAlert Extreme H ₂ S (high range)
GAXT-H	GasAlert Extreme H ₂ S
GAXT-P	GasAlert Extreme PH ₃
GAXT-S	GasAlert Extreme SO ₂
GAXT-C	GasAlert Extreme Cl ₂
GAXT-A	GasAlert Extreme NH ₃
GAXT-D	GasAlert Extreme NO ₂
GAXT-Z	GasAlert Extreme HCN

Order Number	Description
GAXT-E	GasAlert Extreme ETO
GAXT-V	GasAlert Extreme ClO ₂
GAXT-G	GasAlert Extreme O ₃
GAXT-N	GasAlert Extreme NO

Add **-ML** to the end of the order number for detectors with the multi-language option.

Add **-DL** to the end of the order number for detectors with the datalogging and multi-language option.

GasAlert Extreme

Introduction

Warning

To ensure your personal safety, read “Safety Information” before you use the detector.

The GasAlert Extreme gas detector (“the detector”) warns of hazardous gas at levels above a factory set alarm setpoint. This product is a gas detector, not a measurement device.

The detector is a personal safety device. It is your responsibility to respond properly to the alarms.

Table 1 lists the GasAlert Extreme models. This manual includes examples from each model.

Table 1. GasAlert Extreme Models

Model	Gas Monitored
GasAlert Extreme O ₂	Oxygen (% by volume)
GasAlert Extreme CO	Carbon monoxide (ppm) Low H ₂ sensitivity

Model	Gas Monitored
GasAlert Extreme CO	Carbon monoxide (ppm)
GasAlert Extreme H ₂ S	Hydrogen sulfide (ppm) High range
GasAlert Extreme H ₂ S	Hydrogen sulfide (ppm)
GasAlert Extreme PH ₃	Phosphine (ppm)
GasAlert Extreme SO ₂	Sulfur dioxide (ppm)
GasAlert Extreme Cl ₂	Chlorine (ppm)
GasAlert Extreme NH ₃	Ammonia (ppm)
GasAlert Extreme NO ₂	Nitrogen dioxide (ppm)
GasAlert Extreme HCN	Hydrogen cyanide (ppm)
GasAlert Extreme ETO	Ethylene oxide (ppm)
GasAlert Extreme ClO ₂	Chlorine dioxide (ppm)
GasAlert Extreme O ₃	Ozone (ppm)
GasAlert Extreme NO	Nitric oxide (ppm)

Contacting BW Technologies

To contact BW Technologies, call:

USA: 1-888-749-8878

Canada: 1-800-663-4164

Europe: +44 (0) 1869 233004

Middle East: +971-4-8871766

China: +852-2974-1783

Australia: +61-7-3818-8244

Anywhere in the world: +1-403-248-9226

Address correspondence to:

BW Technologies Ltd.
2840 – 2 Avenue S.E.
Calgary, AB T2A 7X9
CANADA

Or visit us on the World Wide Web: www.gasmonitors.com

ISO 9001

Safety Information - Read First

Use the detector only as specified in this manual, otherwise the protection provided by the detector may be impaired.

International symbols used on the detector and in this manual are explained in Table 2.

Read the **Warnings** and **Cautions** on the following pages before using the detector.



This instrument contains a lithium battery. Do not mix with the solid waste stream. Spent batteries should be disposed of by a qualified recycler or hazardous materials handler.

⚠ Caution

To avoid possible personal injury:



- ⇒ **Warning:** Substitution of components may impair intrinsic safety.
- ⇒ **Warning:** To prevent ignition of flammable or combustible atmospheres, disconnect power before servicing.
- ⇒ Do not use the detector if it is damaged. Before you use the detector, inspect the case. Look for cracks or missing plastic.
- ⇒ If the detector is damaged or something is missing, contact [BW Technologies](#) immediately.
- ⇒ Make sure the back is closed and fastened before you operate the detector.
- ⇒ Use only a sensor specifically designed for your GasAlert Extreme model. (See the section, [Replacement Parts and Accessories.](#))
- ⇒ Make sure the sensor screen is not blocked.
- ⇒ Periodically test the sensor's response to gas by exposing the detector to a targeted gas concentration that exceeds the high alarm setpoint. Manually verify that the audible and visual alarms are activated.
- ⇒ Calibrate the detector before first-time use, and then at least once every 180 days. (For HCN detectors, calibrate once every 90 days.)
- ⇒ Do not turn off the detector during a work shift. Turning off the detector resets the TWA (time-weighted average), STEL (short-term exposure limit), and maximum gas exposure values to 0. (See the section, [Alarms.](#))
- ⇒ Use only the following battery: Energizer 1CR2. (See the section, [Replacing the Battery or Sensor.](#))
- ⇒ To reduce the risk of ignition of a flammable atmosphere, batteries must only be changed in an area known to be nonflammable.

⚠ Caution

To avoid possible damage to the detector:

- ⇒ **Do not expose the detector to electrical shock and/or severe continuous mechanical shock.**
- ⇒ **Do not attempt to disassemble, adjust, or service the detector unless instructions for that procedure are contained in the manual and/or that part is listed as a replacement part. Use only BW Technologies replacement parts.**
- ⇒ **The detector Warranty will be voided if customer personnel or third parties damage the detector during repair attempts. Non-BW Technologies repair/service attempts void this Warranty.**
- ⇒ **The Oxygen GasAlert Extreme detector is classified by Underwriters Laboratories Inc. up to an atmosphere of 21% Oxygen.**

Table 2. International Symbols

Symbol	Meaning
	Classified to both U.S. and Canadian Safety standards by Underwriter's Laboratories, Inc.
CE	Conforms to European Union Directives
	European Explosives Protection
ATEX	Conforms to European ATEX Directives
IECEx	International Electrotechnical Commission Scheme for Certification to Standards for Electrical Equipment for Explosive Atmospheres

Getting Started

The items listed below are included with your detector. If the detector is damaged or something is missing, contact the place of purchase immediately.

- 3 V lithium CR2-series battery.
- GasAlert Extreme O₂ model: O₂ sensor;
GasAlert Extreme CO model: CO sensor (low H₂ sensitivity);
GasAlert Extreme CO model: CO sensor;
GasAlert Extreme H₂S model: H₂S sensor (high range);
GasAlert Extreme H₂S model: H₂S sensor;
GasAlert Extreme PH₃ model: PH₃ sensor;
GasAlert Extreme SO₂ model: SO₂ sensor;
GasAlert Extreme Cl₂ model: Cl₂ sensor;
GasAlert Extreme NH₃ model: NH₃ sensor;
GasAlert Extreme NO₂ model: NO₂ sensor;
GasAlert Extreme HCN model: HCN sensor;
GasAlert Extreme ETO model: ETO sensor;
GasAlert Extreme ClO₂ model: ClO₂ sensor;
GasAlert Extreme O₃ model: O₃ sensor;
GasAlert Extreme NO model: NO sensor.
- Test cap and hose.

The detector comes with battery and sensor installed. To order replacement parts and accessories, see the section, [Replacement Parts and Accessories](#).

To become familiar with the features and functions of the detector, study the following figures and tables:

- Figure 1 and Table 3 describe the detector's components.
- Figure 2 and Table 4 describes the detector's display elements.
- Table 5 describes the detector's pushbuttons.

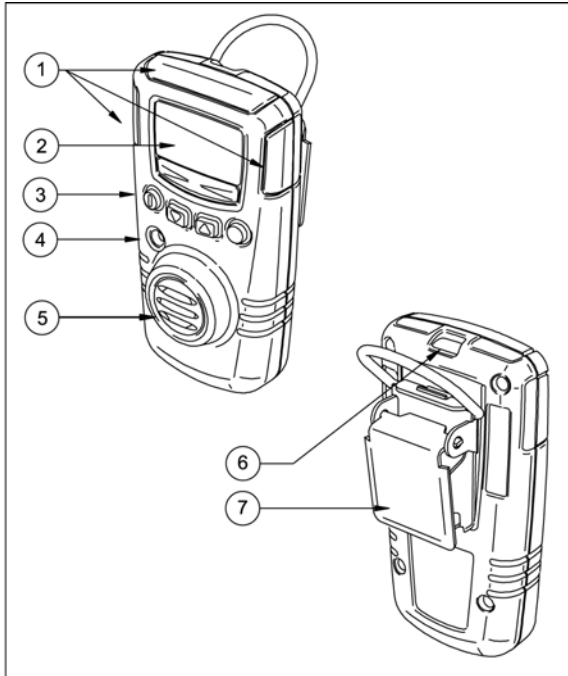

Figure 1. GasAlert Extreme Detector

Table 3. GasAlert Extreme Detector

Item	Function
①	Visual alarm
②	Display
③	Pushbuttons
④	Audible alarm
⑤	Sensor and sensor screen
⑥	Infrared communication port
⑦	Clip

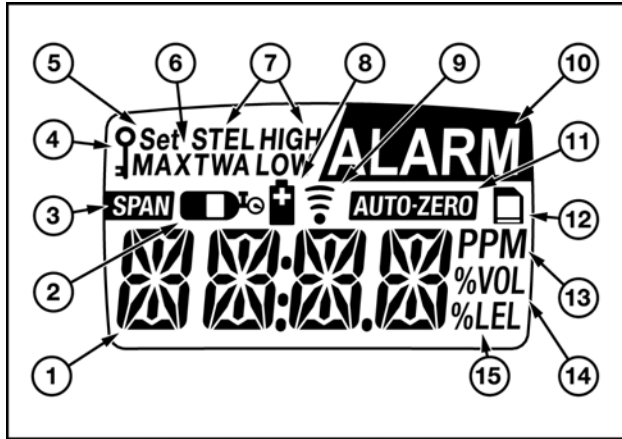

Figure 2. Display Elements



















Note

The display backlight automatically activates for 3 seconds whenever there is insufficient light to view the display (unless it is disabled in the user options) and during alarm conditions. Any pushbutton reactivates the backlight for 6 seconds.

Table 4. Display Elements

Item	Function
①	Numeric value
②	Gas cylinder
③	Automatic span sensor
④	Pass code lock
⑤	Set alarm setpoints and user options
⑥	Maximum gas exposure
⑦	Alarm conditions
⑧	Battery
⑨	Data transmission
⑩	Alarm or alarm setpoint
⑪	Automatically zero sensor
⑫	Optional datalogger indicator
⑬	Parts per million (ppm)
⑭	Percentage by volume (% vol.)
⑮	Percentage by lower explosive limit (% LEL) (future use)

Table 5. Pushbuttons

Pushbutton	Description
	<ul style="list-style-type: none"> • To turn on the detector, press . • To initiate the confidence beep, press  while pressing  at startup. • To turn off the detector, press  and hold for 5 seconds.
	<ul style="list-style-type: none"> • To decrement the displayed value, press . • To enter the user options menu, press  and  simultaneously and hold for 5 seconds. • To initiate calibration and setting alarm setpoints, press and hold  and  simultaneously.
	<ul style="list-style-type: none"> • To increment the displayed value, press . • To view the TWA, STEL and maximum gas exposures, press  and  simultaneously.
	<ul style="list-style-type: none"> • To save the displayed value, press . • To clear TWA, STEL, and maximum gas exposures, press and hold  for 6 seconds.

Activating the Detector

To activate the detector, press .

The detector begins a self-test.

Self-Test

Once the detector is activated, it performs the following checks. (Manually check that all actions occur.)

1. The display shows all the elements.
2. The audible alarm beeps, the visual alarm flashes, the backlight briefly turns on, and the detector emits one vibration.

The detector then conducts a battery test. If the battery is too depleted to continue, the detector performs an automatic shutdown. (Refer to the [Automatic Shutdown Alarm](#) section.)

3. The display shows the date and time in the following order: year, month, day of the month, day of the week, and time.

4. The detector now tests the sensor. If the sensor test fails, the audible alarm emits a slow modulating tone, the visual alarm flashes slowly, and the ALARM icon flashes.



If the sensor test passes, the self-test continues.

5. The gas the detector measures appear on the display.

If the battery is low, the display shows the low battery icon and the self-test continues.



6. The display shows the TWA alarm setpoint.
(Does not apply to O₂.)



7. The display shows the STEL alarm setpoint.
(Does not apply to O₂.)



8. The display shows the low alarm setpoint.



9. The display shows the high alarm setpoint.



10. The display shows the calibration information.

Calibration Due Date

The display shows the following screens:

CAL. DUE XXX DAYS (where 'XXX' represents a number).

It shows the number of days that are left before you need to calibrate your detector. Then the detector enters normal operation.

Calibration Past Due

If the display shows the following screens:

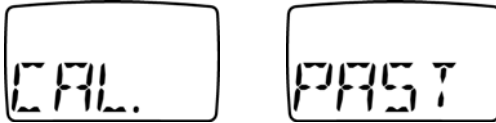

It means the detector is past its calibration due date and it needs to be calibrated before use.

If the calibration is past due, three outcomes could occur:

1. The display toggles the screens **CAL. PAST** until it is acknowledged by pressing \bigcirc . The detector then enters normal operation so a calibration can be performed.
2. The display shows **CAL. PAST** and then performs an automatic shutdown.
3. Press \bigcirc within 5 seconds of the display showing **CAL. PAST**. The display then requests the factory pass code. (Refer to the [Pass Code Protection Option](#) section.)

If an incorrect pass code is entered, the detector will shut down. If the correct pass code is entered, the detector enters normal operation so a calibration can be performed.

Self-Test Pass

If the detector passes the self-test, the detector begins normal operation. The display then shows the ambient gas reading:

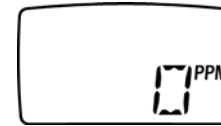

Then the detector starts recording the maximum gas exposure and calculating the time-weighted average (TWA) and short-term exposure limit (STEL).

Self-Test Fail

If the detector fails the self-test, see the [Troubleshooting](#) section.

Deactivating the Detector

To turn off the detector, press and hold  for 5 seconds.

The audible alarm beeps four times and the visual alarm flashes four times. The display then shows the following:



After 3 additional seconds, the display turns off and the detector stops normal operation.

Note



If  is held down for less than 5 seconds, the detector will not shut down.

Confidence Beep

The confidence beep tells you the battery has sufficient power to appropriately respond to a hazardous level of gas and emit an alarm. Instead of beeping when the battery's power is low, the audible alarm beeps to advise you the battery has sufficient power. The confidence beep stops when the battery power is low.

You can only activate the confidence beep at startup.

To turn on the confidence beep:

1. If the detector is on, deactivate the detector.
2. Press  while pressing  at startup.

Upon startup, the detector continuously beeps once every 5 seconds.



To turn off the confidence beep, repeat steps 1 and 2 above.

User Options Menu

The following are the available user options:



1. **EXIT:** Exits the user options menu.
2. **CLCK:** Adjust the date and time of the detector.
3. **PASS:** Enable or disable pass code protection.
4. **STLH:** Enable or disable stealth mode.
5. **BKLT:** Enable or disable the automatic backlight function. (When stealth mode is enabled, this option is not available.)
6. **LTCH:** Enable or disable the latching alarm function.
7. **ACAL:** Enable or disable the automatic Oxygen calibration at startup. (Only available in the GasAlert Extreme Oxygen detector.)
8. **PAST:** Enable or disable automatic shutdown if calibration is past its due date (at startup).
9. **PORT, ESPA, DEUT, FRAN, or ENGL:** Enables the display's language in the user's choice. (Only applicable to detectors with the multi-language feature.)

10. **RATE:** Adjust the datalogger sampling rate. (Only applicable to detectors with the datalogger option.)
11. **SEND:** Transfers datalogs and event logs from the detector to the PC. (Only applicable to detectors with the datalogger option.)

To access the user options menu, press  and  simultaneously until the display reads **OPTN**. Release the buttons and one of the following screens appear:

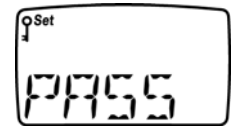
- **PASS:** Pass code protection is on. Once you enter the correct factory pass code, the display will show **EXIT**.
- **EXIT:** Pass code protection is off.



To scroll through the options, press  or .

Note

If you do not press any pushbuttons within 20 seconds of entering the user options menu, the detector returns to normal operation.

GasAlert Extreme

User Manual

Exit Option

To exit the options menu and return to normal operation, press when the display reads **EXIT**.



Date and Time Option

The date and time option allows your detector to track the calibration due date and the datalogger information. Set the date and time to your local settings.

To set the date and time, press when the display shows **CLCK**.



Note

If you do not press any pushbuttons within 10 seconds of entering these displays, the detector automatically retains the existing value.

*If you change one of the values but pause for 10 seconds before pressing , the detector rejects the new value. The display shows **NO** the audible and visual alarms beep and flash six times, and the detector retains the original value.*

Enter the current year. Press to scroll and to confirm your selection.



Enter the month. Press and to scroll, and press to confirm your selection.



Enter the day. Scroll to the correct day and press to confirm your selection.



Scroll to the correct day of the week and press to confirm your selection.



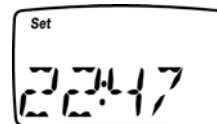

This is a 24-hour clock. Enter the hour and press to confirm your selection. Then enter the minutes and press to confirm your selection.





Date and time settings are complete after your last confirmation.

Pass Code Protection Option

Pass code protection prevents unauthorized personnel from having access to the user options menu, calibration function, and alarm setpoint adjust function.

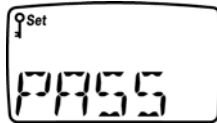
If pass code protect is enabled, press  and  to scroll to the correct pass code when the following screen appears.



Then press  to accept the displayed pass code.

The detector is shipped with the pass code protection off.

Entering the Pass Code Protect Option

To enter the pass code protection option, press  when the display reads **PASS**.

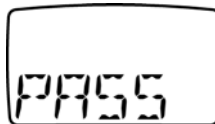

To Activate Pass Code Protection

As the **PASS** display is flashing, scroll to the correct pass code and press .

Note

The factory pass code is provided separately.

The next screen shows that you are about to set pass code protection on. Press  to confirm.



To Deactivate Pass Code Protection

If pass code protection is already activated, the following screen appears after you enter the pass code option:



Press  to deactivate pass code protection.

GasAlert Extreme

User Manual

Stealth Mode Option

Stealth mode disables the backlight and the audible and visual alarms. The detector is shipped with stealth mode disabled.

To enter the stealth mode option, press when the display shows **STLH**.



The display flashes **ON** if you are about to enable the option, or **OFF** if you are about to disable the option. You can toggle between **ON** and **OFF** by pressing or . Then press to confirm your selection.



When stealth mode is enabled, **STLH** constantly appears on the display unless the reading is not 0 ppm for toxics or 20.9% vol. for Oxygen.

Note

The vibrator alarm is disabled at -20°C.

Automatic Backlight Option

This option allows you to disable the automatic backlight of the detector so regardless of the current lighting situation it does not activate.

The detector is shipped with the automatic backlight function enabled.

To enter the automatic backlight option, press when the display reads **BKLT**.

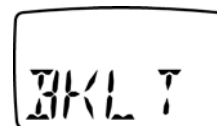

The display then advises whether you are enabling (**ON**) or disabling (**OFF**) the option. Press to confirm your selection.

If the option is enabled, the backlight automatically turns on whenever there is insufficient light to view the display.

If the option is disabled, you have to press to turn on the backlight if the detector is in low light conditions.

Latching Alarm Option

The latching alarm option allows an alarm to remain active until the user acknowledges the alarm by pressing .

The detector is shipped with the latching alarm function disabled.

To enter the latching alarm option, press when the display reads **LTCH**.

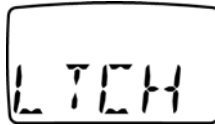

The display advises whether you are enabling or disabling the latching alarm function. Press to confirm your selection.

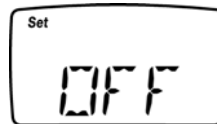

Automatic Oxygen Calibration Option

This option allows you to enable or disable the automatic Oxygen calibration. Enabling this option allows the GasAlert Extreme Oxygen detector to calibrate its sensor during startup. (Sensor is calibrated after the display shows when the next calibration is due.)

The detector is shipped with this function disabled.

To enter the automatic Oxygen calibration option, press when the display reads **ACAL**.

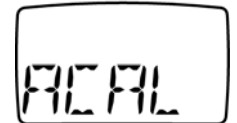

The display then advises whether you are enabling (**ON**) or disabling (**OFF**) the option. Press to confirm your selection.

Calibration Past Protection Option

This option allows you to enable an automatic shutdown at startup if the detector is past due for a calibration.

The detector is shipped with this option disabled.

To enter the calibration past protection option, press when the display reads **PAST**.

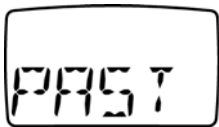

The display then advises whether you are enabling (**ON**) or disabling (**OFF**) the option. Press to confirm your selection.

Languages Option

If your detector has the multi-language feature, you can choose to view your display in the following five languages:

- Portuguese (**PORT**);
- Spanish (**ESPA**);
- German (**DEUT**);
- French (**FRAN**); and
- English (**ENGL**).

The detector is shipped with English as the language default.

Scroll to the appropriate language and press to confirm your choice.

Datalogger Sampling Rate Option

The detector is shipped with the datalogger set to record a sample every 5 seconds. This sample rate can be from 1 to 60 seconds.

To adjust the datalogger sampling rate, press when the display shows **RATE**.



Use and to change the sampling rate and then press to confirm your selection.



Data Transfer Option

This option transfers the datalog/event log information from the detector to the PC.

Note

You need an IR DataLink (or other BW accessory) in order to transfer the data from the detector to the PC.

To enter the data transfer option, press when the display shows **SEND**.



Once you are inside this option you can transfer the information in one of the following three ways:

- **EVNT:** Transfers all of the events.
- **LAST:** Sends all of the datalogs since the last time they were downloaded.
- **ALL:** Sends all of the datalogs saved on the detector.

Once you select one of the three options, the display will administer a countdown to indicate that the data is transferring.



The number that the countdown begins at is dependant upon the amount of data that is being transferred.

Note

When you transfer event logs nothing appears on the display to indicate it is transferring because there is little data to transfer.

After the transfer is complete, the display reads **EXIT**.

If the connection between the detector and the IR DataLink is disturbed during a transfer, the following display appears before exiting to the user options menu.



Note

*If the transfer fails, selecting **LAST** will resume the transfer from where the initial send failed. To ensure that you do not delete the previously transferred data, either save the already transferred data before selecting **LAST**, or select **ALL** to ensure the previously downloaded data is transferred again.*

Datalog and Event Log

The GasAlert Extreme datalogger version allows the detector to record various information so a report can be compiled.

Datalog

Datalog information is recorded based on the sampling rate set in the detector's user options. The following information is recorded in a datalog:

- The date and time;
- The detector's serial number;
- The type of gas the detector monitors;
- The current gas reading;
- The sensor status;
- The unit status;
- Pass code protect is on/off;

- The period that STEL is calculated;
- Confidence beep is on/off;
- Automatic backlight is on/off;
- Stealth mode is on/off;
- Latching alarm is on/off;
- The calibration past user option is on/off; and
- The language that the display is shown at.

Event Log

An event log is data which is recorded when an event (i.e., an alarm) occurs. The following information is recorded in an event log:

- The detector's serial number;
- The type of exposure the detector experienced;
- The time the alarm started and ended; and
- The peak exposure of the alarm.

Alarms

Table 6 describes detector alarms and shows how the display looks for each alarm.

Table 7 describes the computed gas exposures.

Table 6. Alarms











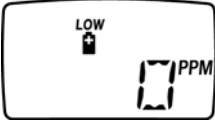

Alarm	Display	Alarm	Display
<p>Low Alarm:</p> <ul style="list-style-type: none"> • Slow modulating tone • Slow flash • ALARM flashes • Slow vibrations 		<p>TWA Alarm:</p> <ul style="list-style-type: none"> • Slow modulating tone • Slow flash • ALARM flashes • Slow vibrations 	
<p>High Alarm:</p> <ul style="list-style-type: none"> • Fast modulating tone • Fast flash • ALARM flashes • Fast vibrations 		<p>STEL Alarm:</p> <ul style="list-style-type: none"> • Fast modulating tone • Fast flash • ALARM flashes • Fast vibrations 	
<p>Sensor Alarm:</p> <ul style="list-style-type: none"> • Slow modulating tone • Slow flash • ALARM flashes • Slow vibrations 		<p>Low Battery Alarm:</p> <ul style="list-style-type: none"> • 1 beep, 1 flash every 5 seconds and 1 quick vibration every minute (confidence beep disabled) • No beeps, flashes, or vibrations (confidence beep enabled) 	

Table 6. Alarms (cont.)

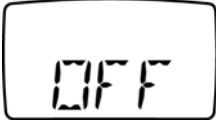
Alarm	Display	Alarm	Display
Automatic Shutdown Alarm: (Low battery) <ul style="list-style-type: none"> • 8 beeps, flashes, and vibrations • LOW  displays 		Automatic Shutdown Alarm: (Calibration past) <ul style="list-style-type: none"> • 8 beeps, flashes, and vibrations 	
After Automatic Shutdown: (Low battery) <ul style="list-style-type: none"> • No modulating tone • No flash or vibrations •  displays for a short time 		Confidence Beep: <ul style="list-style-type: none"> • 1 beep every 5 seconds • 1 quick vibration per minute 	

Note

During an alarm condition, the detector activates the backlight and the display shows the current ambient gas reading.

The high alarm and STEL alarm have the same priority. A high alarm and/or STEL alarm override a low alarm and/or TWA alarm. To check STEL and TWA alarms specifically, press and hold  and  simultaneously.

The vibrator alarm is disabled at -20°C.

Computed Gas Exposures

Warning

To avoid possible personal injury, do not turn off the detector during a work shift. The detector automatically resets the TWA, STEL, and maximum gas exposures at startup. If you restart the detector during a work shift, these values will not reflect the entire work shift.



Table 7. Computed Gas Exposures

Gas Exposure	Description
TWA	<ul style="list-style-type: none">• Time-weighted average based on an 8-hour workday.• Accumulated value.
STEL	<ul style="list-style-type: none">• Time-weighted average based on a 15-minute period.• Accumulated value.
Maximum*	<ul style="list-style-type: none">• Highest gas level encountered during the period the detector is turned on.

*Maximum gas exposure for Oxygen describes the furthest level reached from 20.9% vol.

Viewing Gas Exposures

Toxic Gases

Press  and  simultaneously and the display first shows the TWA gas exposure.

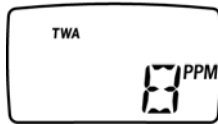

The display then shows the STEL gas exposure.

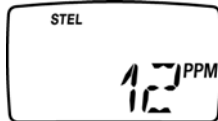



The display then shows the maximum gas exposure.



Press  and hold for 6 seconds to clear the TWA, STEL, and maximum gas exposure. The detector emits two beeps and two vibrations to confirm that the exposures have been cleared.

Oxygen

If you have an Oxygen detector, pressing  and  simultaneously displays both the very low and very high levels of Oxygen exposure.



Gas Alarm Setpoints

The detector's gas alarm setpoints trigger the gas alarms described in the table below.

Table 8. Gas Alarm Setpoints

Alarm	Condition
TWA Alarm	TWA above TWA alarm setpoint. (O ₂ : Not applicable)
STEL Alarm	STEL above STEL alarm setpoint. (O ₂ : Not applicable)
Low Alarm	Toxic Gases: Ambient gas level above low alarm setpoint. O ₂ : Ambient gas level may be set to above or below 20.9%.
High Alarm	Ambient gas level above high alarm setpoint. O ₂ : Ambient gas level may be set to above or below 20.9%.

Resetting Gas Alarm Setpoints

Note

Standard factory alarm setpoints vary by region.

Table 9 lists the factory alarm setpoints.

Table 9. Factory Alarm Setpoints

Gas	TWA	STEL	Low	High
O ₂	N/A	N/A	19.5% vol.	22.5% vol.
CO (low H ₂)	35 ppm	200 ppm	35 ppm	200 ppm
CO	35 ppm	200 ppm	35 ppm	200 ppm
H ₂ S (high range)	10 ppm	15 ppm	10 ppm	15 ppm
H ₂ S	10 ppm	15 ppm	10 ppm	15 ppm
PH ₃	0.3 ppm	1.0 ppm	0.3 ppm	1.0 ppm
SO ₂	2.0 ppm	5.0 ppm	2.0 ppm	5.0 ppm
Cl ₂	0.5 ppm	1.0 ppm	0.5 ppm	1.0 ppm
NH ₃	25 ppm	35 ppm	25 ppm	50 ppm
NO ₂	2.0 ppm	5.0 ppm	2.0 ppm	5.0 ppm
HCN	4.7 ppm	10.0 ppm	4.7 ppm	10.0 ppm
ETO	1.0 ppm	5.0 ppm	1.0 ppm	5.0 ppm

Gas	TWA	STEL	Low	High
ClO ₂	0.10 ppm	0.30 ppm	0.10 ppm	0.30 ppm
O ₃	0.10 ppm	0.10 ppm	0.10 ppm	0.20 ppm
NO	25 ppm	25 ppm	25 ppm	25 ppm

To change the factory alarm setpoints, refer to the section [Calibration and Setting Alarm Setpoints](#).

Note

You can disable an alarm by setting the alarm setpoint to 0.

The ETO sensor is extremely cross sensitive and it responds strongly to CO.

Stopping a Gas Alarm

The low and high alarms stop when the ambient gas level returns to the acceptable range.

The detector computes the TWA and STEL value. If the value is above the alarm setpoint, the detector activates to TWA and/or the STEL alarm. To stop the TWA and/or STEL alarm, press and hold  for 6 seconds, or deactivate the detector.

Acknowledge Latched Alarm

If an alarm is set to latch, the audible and visual alarms persist in the event of an alarm condition until it is acknowledged.

To acknowledge a latched alarm condition, press  to reset the latched alarm when the gas level present has dropped below the alarm setpoint.

Sensor Alarm

The detector tests for a missing or defective sensor during the activation self-test. See the [Troubleshooting](#) section.

Low Battery Alarm

The detector tests the battery during the activation self-test and continuously thereafter. If the battery voltage is low, the detector activates the low battery alarm.

The low battery alarm continues until you replace the battery or the battery power is almost depleted. If the battery voltage drops too low, the detector executes an automatic shutdown.

Note

If the confidence beep is on, the audible alarm does not beep during a low battery alarm. See the [Confidence Beep](#) section.

Automatic Shutdown Alarm

There are two situations where an automatic shutdown alarm occurs:

1. If the battery voltage is in immediate danger of dropping below the minimum operating voltage, the audible alarm beeps 8 times, the visual alarm flashes 8 times, and the detector emits 8 vibrations. After 3 seconds, the display blanks out and the detector stops normal operation. The display shows  periodically until the battery power is depleted.

For directions on how to replace the battery, see the section [Replacing the Battery or Sensor](#).

Note

Typically, the low battery alarm continues for 30 minutes before an automatic shutdown.

2. If the calibration past protection user option is active and the detector is past its calibration due date, the detector will go into an automatic shutdown.

Calibration and Setting Alarm Setpoints

Guidelines

When calibrating the detector, adhere to the following guidelines.

- Recommended gas mixture:
 - O₂: Clean Air, 20.9% vol.
 - CO (low H₂ sensitivity): 50 to 500 ppm balance N₂
 - CO: 50 to 500 ppm balance N₂
 - H₂S (high range): 10 to 100 ppm balance N₂
 - H₂S: 10 to 100 ppm balance N₂
 - PH₃: 1 to 5 ppm balance N₂
 - SO₂: 10 to 50 ppm balance N₂
 - Cl₂: 3 to 25 ppm balance N₂
 - NH₃: 20 to 100 ppm balance N₂
 - NO₂: 5 to 50 ppm balance N₂
 - HCN: 5 to 20 ppm balance N₂
 - ETO: 5 to 50 ppm balance N₂
 - ClO₂: 0.1 to 1.0 ppm balance N₂
 - O₃: 0.1 to 1.0 ppm balance N₂
 - NO: 10 to 250 ppm balance N₂
- For ETO detectors (before each use) allow the instrument to fully stabilize in the temperature that it is to be operated in and then zero the detector.
- It is necessary to periodically re-zero the ETO detector.
- Calibration accuracy is never better than the calibration gas accuracy. BW Technologies recommends a premium grade calibration gas. Gases with NIST (National Institute of Standards and Technology) traceable accuracy will improve the validity of the calibration. Do not use a gas cylinder beyond its expiration date.
- Calibrate a new sensor before use. Allow the sensor to stabilize before starting calibration (used: 60 seconds; new: 5 minutes).
- Calibrate the detector at least once every 180 days (for HCN detectors calibrate at least once every 90 days), depending on use and sensor exposure to poisons and contaminants.
- Calibrate the detector if the ambient gas display varies at startup.
- It is best to calibrate the sensor before changing the alarm setpoints.
- Calibrate only in a clean atmosphere, which is free of background gas.
- To disable an alarm, set its alarm setpoint to 0.
- If you require a certified calibration, contact [BW Technologies](#).

Test Cap

The test cap and hose, which are shipped with the detector, simplify the sensor testing and calibration. Table 10 and Figure 3 show how to use the test cap and hose when applying gas to the sensor.

Table 10. Test Cap

Item	Description
①	Test cap
②	Hose
③	Regulator and gas cylinder

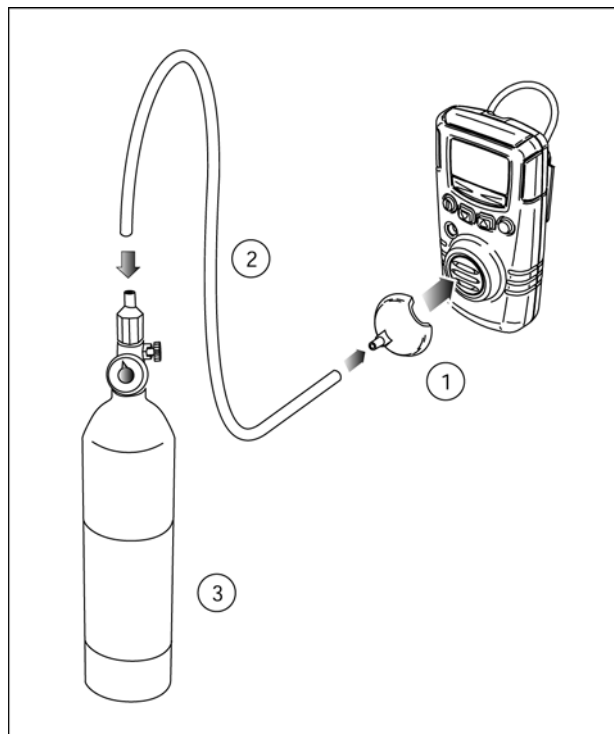



Figure 3. Test Cap

Calibration Procedure



To calibrate the detector and set its alarm setpoints, perform the following procedure.

Note

To quit at any point, press . The detector retains any saved values and emits four beeps and four vibrations before returning to normal operation.

Calibrate O₂ in clean air.

Start Calibration

1. Press  and  simultaneously until the display shows the following.



The audible alarm beeps once.

Auto Zero

2. The display flashes **AUTO-ZERO** while the detector automatically zeroes the sensor.

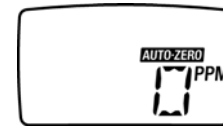

The audible alarm then beeps twice.

Note

Do not apply the calibration gas until the display shows a flashing gas cylinder; otherwise, the auto zero step will fail.

If the sensor fails the auto zero step, the display shows **FAIL**, the detector skips the sensor span steps and goes to the alarm setpoints. Press  to exit. Then restart calibration in an atmosphere that is clear of the targeted gas. If the step fails a second time, restart the detector to test the sensors.

Pass Code Protect Activated

After a successful auto zero, the detector asks for the pass code if the detector is pass code protected. The pass code needs to be entered before proceeding to auto span and alarm setpoints.

3. The display will advise calibration is locked. It then requests the pass code. (Refer to [Pass Code Protection Option](#).)

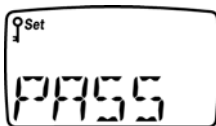

Note

If the correct code is entered, the detector beeps twice and automatically proceeds to set span.

*If the pass code is not entered within 10 seconds or the wrong pass code is entered, the detector displays **NO**.*



The detector then beeps four times and automatically returns to normal operation.

Set Span

The display shows the current calibration gas setting.



The display flashes prompting you to input a new calibration gas concentration, or you can accept the current value for the span (sensitivity adjustment).

4. To change the calibration gas setting, press or until the display matches the concentration of the calibration gas.
5. Press to save the new value.

Note

If you do not press any pushbuttons within 10 seconds of viewing this display, the detector automatically saves the displayed concentration of the calibration gas.

*If you change the calibration gas concentration but pause for 10 seconds before pressing , the detector rejects the new value. The display shows **NO**, the audible alarm beeps six times, and the detector retains the original value.*

GasAlert Extreme

User Manual

Span

The display now shows a flashing gas cylinder prompting you to apply a calibration gas to the sensor or you can skip the span.

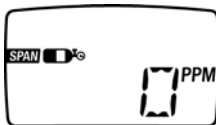

Note

If you skip the span, you cannot change the calibration date.

The flashing gas cylinder does not appear if you have an Oxygen detector.

6. Apply gas to the sensor at a flow rate of 500 ml/min.
(for NH₃, Cl₂, and ETO: 1000 ml/min.)
OR
Press  to skip the span.

The gas reading will change as gas is applied to the sensor. When the detector senses approximately a quarter of the expected gas concentration (30 seconds), the audible alarm beeps once. The detector then begins spanning the sensor.

NH₃, Cl₂, ClO₂, O₃, and ETO: 5 minutes; O₂: 30 seconds; other gases: 2 minutes (approximately).

The audible alarm beeps three times at the end of the span.

Note

The detector will not span a sensor if:

- You do not apply gas to the sensor.
- The sensor fails to detect at least a quarter of the expected gas concentration in the first 30 seconds.
- The gas concentration drops below one-half of the expected gas level during the 2-minute span.

*If the detector fails to span a sensor, the display shows **FAIL** and the audible and visual alarms beep and flash six times (unless you pressed  to skip the span). You then proceed to the alarm setpoints.*



If you apply gas to a sensor and the detector fails to span the sensor, press  to exit the calibration and repeat the calibration process using a new gas cylinder. If the sensor fails the span a second time, replace the sensor. (See the section, [Replacing the Battery or Sensor.](#))

Setting the Calibration Due Date

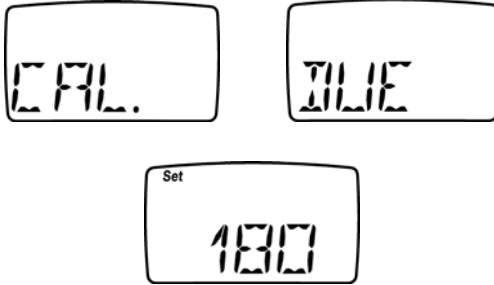
After a successful calibration, the display shows the number of days remaining before the next calibration is due. (The default setting is 180 days.)



The display flashes prompting you to change the calibration due date between 1 and 365 days.

7. If you want to change the next calibration due date, press  or  until the display shows the new value.
8. Press  to save the new value.

Note



If you do not press any pushbuttons within 10 seconds of entering this display, the detector automatically retains the existing value.

Setting the TWA Alarm Setpoint

The display now shows the TWA alarm setpoint.



The display flashes, prompting you to input a new TWA alarm setpoint.

9. If you want to change the TWA alarm setpoint, press  or  until the display shows the new value.
10. Press  to save the new value.

Note

If you do not press any pushbuttons within 10 seconds of entering the TWA alarm display, the detector automatically retains the existing value.



*If you change the displayed value but pause for 10 seconds before pressing , the detector rejects the new value. The display shows **NO**, the audible and visual alarms beep and flash six times, and the detector retains the original value.*

Setting the STEL Alarm Setpoint

The display shows the STEL alarm setpoint.



The display flashes prompting you to input a new STEL alarm setpoint.

11. If you want to change the STEL alarm setpoint, press  or  until the display shows the new value.
12. Press  to save the new value.

Note

If you do not press any pushbuttons within 10 seconds of viewing this display, the detector automatically retains the existing STEL alarm setpoint.



*If you change the STEL alarm value but pause for 10 seconds before pressing , the detector rejects the new value. The display shows **NO**, the audible and visual alarms beep and flash six times, and the detector retains the original value.*

Setting the Low Alarm Setpoint

The display now shows the current low alarm setpoint.



The display flashes prompting you to input a new low alarm setpoint.

13. If you want to change the low alarm setpoint, press  or  until the display shows the new value.
14. Press  to save the new value.

Note

If you do not press any pushbuttons within 10 seconds of entering the low alarm display, the detector automatically retains the existing value.



*If you change the low alarm value but pause for 10 seconds before pressing , the detector rejects the new value. The display shows **NO**, the audible and visual alarms beep and flash six times, and the detector retains the original value.*

Setting the High Alarm Setpoint

The display shows the high alarm setpoint.



The display flashes prompting you to input a new high alarm setpoint.

15. If you want to change the high alarm setpoint, press  or  until the display shows the new value.
16. Press  to save the new value.

Note

If you do not press any pushbuttons within 10 seconds of viewing this display, the detector automatically retains the existing high alarm setpoint.

*If you change the high alarm setpoint but pause for 10 seconds before pressing , the detector rejects the new value. The display shows **NO**, the audible and visual alarms beep and flash six times, and the detector retains the original value.*

At the end of the calibration procedure the audible alarm beeps four times and the detector returns to normal operation.

Verification

After calibration is complete and the unit is in normal operating mode, test the detector using a gas cylinder other than the one used in calibration. The gas concentration should not exceed the sensor's detection range. Confirm that the display shows the expected concentration.

Maintenance

To keep the detector in good operating condition, perform the following basic maintenance as required:

- Calibrate, test, and inspect the detector at regular intervals.
- Keep an operations log of all maintenance, calibrations, and alarm events.
- Clean the exterior with a soft damp cloth. Do not use solvents, soaps, or polishes.
- Do not immerse the detector in liquids.

Cleaning a Sensor Screen

Remove the screen. Clean using a soft, clean brush and clean, warm water. Let the screen dry before replacing it.

Cleaning a Sensor

Remove the sensor. Clean using a soft, clean brush. Do not use water.

Note

It is recommended that you apply a test gas and test the detector's response to gas following any cleaning procedure.

Clearing a Sensor

The sensor has a high degree of resistance to common vapors and gases. The sensor will most likely clear itself if you move the detector to a clean environment and wait 10 to 30 minutes.

Do not expose a sensor to the fumes of inorganic solvents (e.g., paint fumes) or organic solvents.

Replacing the Battery or Sensor

⚠ Warning

To avoid possible personal injury:

Replace the battery as soon as the detector emits a low battery alarm.

Use only the Energizer 1CR2 battery.

Use only the sensor specifically designed for your GasAlert Extreme model. Otherwise, the detector will not monitor the target gas. (See the section, Replacement Parts and Accessories.)

Note

When you remove the battery from the detector, the clock will revert back to its default value.

To preserve battery life, turn the detector off when you are not using it.

Figure 4 and Table 11 illustrate how to replace the battery or sensor. If the detector is on, shut down the detector before replacing the battery or sensor. Use a Phillips head screwdriver to loosen and tighten any screws.

Do not use excessive force when removing or inserting the sensor, or the sensor can be damaged. Gently rocking the sensor back and forth may help free a tightly held sensor.

When placing the sensor screen back, ensure that the shiny side is facing away from the sensor.

The sensor provides consistent and accurate ambient gas readings. The sensor lasts 2 years under normal operation.

After replacing a sensor or battery, ensure that the detector's back screws are torqued to 3-4 in-lbs in a crisscross pattern to ensure a proper environment seal.

The [Troubleshooting](#) section describes the problems caused by a sensor in need of calibration or replacement.

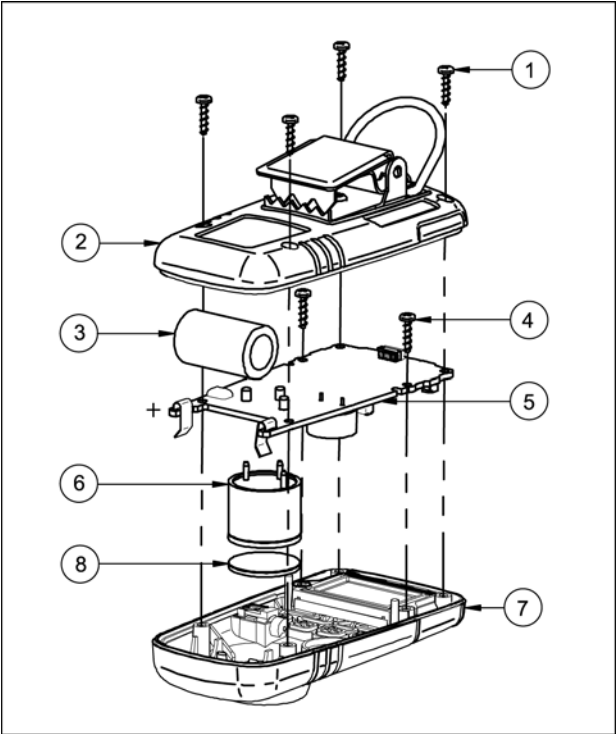

Figure 4. Replacing the Battery or Sensor

Table 11. Replacing the Battery or Sensor

Item	Description
①	Detector back screws
②	Detector back
③	Battery
④	Main board screws
⑤	Main board
⑥	Sensor
⑦	Detector front
⑧	Sensor screen

Troubleshooting

This section describes the various problems you may encounter with your detector and how you can fix those problems.

The detector's electronics are protected from variations in humidity and corrosive atmospheres. If you encounter a problem, try the solutions listed in the following table.

If you still are unable to correct the problem, contact [BW Technologies](#).

Table 12. Troubleshooting Tips

Problem	Possible Cause	Solution
The detector does not turn on.	<ul style="list-style-type: none">→ No battery→ Depleted battery→ Damaged or defective detector→ Reversed battery	<ul style="list-style-type: none">→ Install battery→ Replace battery→ Contact BW→ Reinstall battery correctly
The detector enters alarm mode immediately when it is turned on.	<ul style="list-style-type: none">→ Sensor needs to stabilize→ Low Battery alarm→ Sensor alarm	<ul style="list-style-type: none">→ Used sensor: wait 60 seconds New sensor: wait 5 minutes→ Replace battery→ Replace sensor

Table 12. Troubleshooting Tips (cont.)

Problem	Possible Cause	Solution
The activation self-test fails during one of the checks.	<ul style="list-style-type: none"> → General fault → Alarm setpoints are incorrect 	<ul style="list-style-type: none"> → Contact BW → Reset alarm setpoints
The detector does not display normal ambient gas reading after activation self-test.	<ul style="list-style-type: none"> → Sensor not stabilized → Detector requires calibration → Targeted gas is present 	<ul style="list-style-type: none"> → Used sensor: wait 60 seconds → New sensor: wait 5 minutes → Calibrate detector → Detector is operating properly. Use caution in suspect areas.
The detector does not respond to the pushbuttons.	<ul style="list-style-type: none"> → Battery is depleted → Detector is performing operations that do not require user input 	<ul style="list-style-type: none"> → Replace battery → Pushbutton operation restores automatically when the operation ends
The detector does not accurately measure the gas.	<ul style="list-style-type: none"> → Detector requires calibration → Detector is colder/hotter than ambient gas → Sensor screen is blocked 	<ul style="list-style-type: none"> → Calibrate sensor → Allow detector to acquire ambient temperature before use → Clean sensor screen

Table 12. Troubleshooting Tips (cont.)

Problem	Possible Cause	Solution
The detector does not enter alarm.	<ul style="list-style-type: none"> → Alarm setpoint(s) are set incorrectly → Alarm setpoint(s) set to zero → Detector is in calibration mode 	<ul style="list-style-type: none"> → Reset alarm setpoints → Reset alarm setpoints → Complete the calibration procedure
The detector intermittently enters alarm without apparent reason.	<ul style="list-style-type: none"> → Ambient gas levels are near alarm setpoint or the sensor is exposed to a puff of the targeted gas → Alarms set incorrectly → Missing or faulty sensor 	<ul style="list-style-type: none"> → Detector is operating normally. Use caution in suspect areas. Check maximum gas exposure reading. → Reset alarm setpoints → Replace sensor
The detector automatically shuts off.	<ul style="list-style-type: none"> → Automatic shutdown feature activated due to weak battery 	<ul style="list-style-type: none"> → Replace battery
Unit will not auto zero or calibrate; O ₂ sensor reading is erratic.	<ul style="list-style-type: none"> → Sensor may be expired 	<ul style="list-style-type: none"> → Change the sensor

Replacement Parts and Accessories

Warning

To avoid personal injury or damage to the detector, use only specified replacement parts.

To order any parts or accessories, contact [BW Technologies](#).

Table 13. Replacement Parts and Accessories

Model No.	Description	Qty
SR-X10	Replacement O ₂ sensor	1
SR-M204	Replacement CO (low H ₂ sensitivity) sensor	1
PS-RM04	Replacement CO sensor	1
PS-RH04S	Replacement H ₂ S sensor	1
SR-P04	Replacement PH ₃ sensor	1
PS-RS04	Replacement SO ₂ sensor	1
PS-RC10	Replacement Cl ₂ sensor	1
SR-A04	Replacement NH ₃ sensor	1
PS-RD04	Replacement NO ₂ sensor	1
PS-RZ10	Replacement HCN sensor	1
SR-E04	Replacement ETO sensor	1
SR-V04	Replacement ClO ₂ sensor	1

Model No.	Description	Qty
SR-G04	Replacement O ₃ sensor	1
SR-N04	Replacement NO sensor	1
GA-SS	Sensor screens	10
GA-TC-1	Test cap and hose	1
GA-HC-1	Hard hat clip	1
GA-AG-1	Alligator clip (non-conductive)	1
GA-AG-2	Alligator clip (stainless-steel)	1
REG-0.5	Gas regulator (0.5 L/min)	1
G0042-H25	Calibration gas, H ₂ S (58 L)	1
CG2-M-200-103	Calibration gas, CO (103 L)	1
CG2-S-25	Calibration gas, SO ₂ (58 L)	1
CG2-C-5	Calibration gas, Cl ₂ (58 L)	1
CG2-Z-10	Calibration gas, HCN (58 L)	1
CG2-D-10	Calibration gas, NO ₂ (58 L)	1
CG2-P-1-58	Calibration gas, PH ₃ (58 L)	1
GA-USB2	IR DataLink	1

Specifications

Operating temperature:

H₂S, SO₂, HCN: -40°C to +50°C (-40°F to +122°F)

CO: -30°C to +50°C (-22°F to +122°F)

Other gases: -20°C to +50°C (-4°F to +122°F)

Operating humidity:

CO, H₂S, SO₂, Cl₂, HCN, NO₂, NH₃, PH₃, ETO, NO, O₃:

15% to 90% relative humidity (non-condensing)

Cl₂: 10% to 95% relative humidity (non-condensing)

ClO₂: 15% to 95% relative humidity (non-condensing)

O₂: 0% to 99% relative humidity (non-condensing)

Detection ranges:

GasAlert Extreme O₂: 0 – 30.0% vol. (0.1% vol. increments)

GasAlert Extreme CO (low H₂ sensitivity): 0 – 1000 ppm

(1 ppm increments)

GasAlert Extreme CO: 0 – 1000 ppm (1 ppm increments)

GasAlert Extreme H₂S (high range): 0 – 500 ppm

(1 ppm increments)

GasAlert Extreme H₂S: 0 – 100 ppm (1 ppm increments)

GasAlert Extreme PH₃: 0 – 5.0 ppm (0.1 ppm increments)

GasAlert Extreme SO₂: 0 – 100.0 ppm (0.1 ppm increments)

GasAlert Extreme Cl₂: 0 – 50.0 ppm (0.1 ppm increments)

GasAlert Extreme NH₃: 0 – 100 ppm (1 ppm increments)

GasAlert Extreme NO₂: 0 – 100.0 ppm (0.1 ppm increments)

GasAlert Extreme HCN: 0 – 30.0 ppm (0.1 ppm increments)

GasAlert Extreme ETO: 0 – 100.0 ppm (0.1 ppm increments)

GasAlert Extreme ClO₂: 0 – 1 ppm (0.01 ppm increments)

GasAlert Extreme O₃: 0 – 1 ppm (0.01 ppm increments)

GasAlert Extreme NO: 0 – 250 ppm (1 ppm increments)

Sensor type: Plug-in electrochemical cells

Calibration: Auto zero, set span, and span sensor

Alarm conditions: TWA alarm, STEL alarm, low alarm, high alarm, sensor alarm, low battery alarm, confidence beep, automatic shutdown alarm

Audible alarm: 95 dB at 1 ft. (0.3 m) typical

Visual alarm: Red light-emitting diode (LED)

Display: Alpha-numeric liquid crystal display (LCD)

Backlight: Automatically activates for 3 seconds whenever there is insufficient light to view the display and during alarm conditions. Any pushbutton reactivates the backlight for 6 seconds.

Self-test: Initiated at activation

Battery test: Every 0.5-second

Battery: 3 V lithium Energizer 1CR2-series battery

Intrinsic safety:

Classified by UL to both U.S. and Canadian Standards as intrinsically safe for Class I, Division 1, Group A, B, C, D

European Explosives Protection EEx ia IIC

CE 0539  II 2 G DEMKO 04 ATEX 03 36363

CE  II 1 G EEx ia IIB T4

IECEX

General Specifications for Datalogger Units

Storage: Maximum of 8 months of data at 5-second intervals (based on a normal workweek).

Memory Type: Wrap-around memory ensures most recent data is always saved.

Sample Rate: One reading every 5 seconds (standard).

Data Recorded: All sensor readings, all alarm conditions, calibrations, event flags, battery status, sensor status, confidence beep activation, and detector status along with the time and date and the unit's serial number.

Indicators: Icon advising Datalogger is operating normally.

Transfer Accessory: IR DataLink or other BW accessory.

Support:

BW E.D.M. (Excel Datalog Manager): This software organizes GasAlert Extreme datalog and event log files into a readable report.



D5561/3 English

iERP: 116330

© 2004 BW Technologies. All rights reserved. Printed in Canada.

All product names are trademarks of their respective companies.

