

Dual Relay Module

Manning DRM Instruction and Installation Manual

07/09

Honeywell Confidential & Proprietary

This work contains valuable, confidential, and proprietary information. Disclosure, use or reproduction outside of Honeywell Inc. is prohibited except as authorized in writing. This unpublished work is protected by the laws of the United States and other countries.

Notices and Trademarks

Copyright 2009 by Honeywell International Inc.

Release A July 2009

While this information is presented in good faith and believed to be accurate, Honeywell disclaims the implied warranties of merchantability and fitness for a particular purpose and makes no express warranties except as may be stated in its written agreement with and for its customers.

In no event is Honeywell liable to anyone for any indirect, special or consequential damages. The information and specifications in this document are subject to change without notice.

Manning is a registered trademark of Honeywell International Inc.

Other brand or product names are trademarks of their respective owners.

Honeywell Analytics
405 Barclay Blvd.
Lincolnshire, IL 60069
USA

1-800-538-03

About This Document

World Wide Web

The following Honeywell web sites may be of interest.

Honeywell Organization	WWW Address (URL)
Corporate	www.honeywell.com
Honeywell Analytics	www.honeywellanalytics.com
Manning Gas Detection	www.manningsystems.com

Telephone

Contact us by telephone at the numbers listed below.





Organization		Phone Number
United States	Honeywell Analytics Inc.	1-800-538-0363 1-913-712-5576 1-913-712-5580 Fax
Canada	Honeywell Analytics Inc.	1-888-749-8878
Europe	Honeywell PACE	+44 (0)1202 676161
Asia Pacific	Honeywell Asia Pacific Inc.	+82 (0)2 2025 0307
Middle East	Honeywell Analytics Inc.	+971 4 3458 338

Sales Information

Contact us at detectgas@honeywell.com

Symbol Definitions

The following table lists those symbols used in this document to denote certain conditions.

Symbol	Definition
	ATTENTION: Identifies information that requires special consideration.
	TIP: Identifies advise or hints for the user, often in terms of performing a task.
	REFERENCE-EXTERNAL: Identifies an additional source of information outside of this bookset.
	REFERENCE-INTERNAL: Identifies an additional source of information within this bookset.

Contents

Serial number:

Section	Title	Page
1	System Description	5
2	Installation	6
3	Operation	8
4	Limited Warranty	9

Introduction

This manual has been prepared to help in the use and installation of the Manning DRM Dual Relay Module. This manual will convey the operating details of the alarm system, ensure proper installation, and demonstrate start-up and routine maintenance procedures.



ATTENTION: This manual must be carefully followed by all individuals who have or will have the responsibility for using or servicing the module. Warranties made by Honeywell Analytics with respect to this equipment will be voided if the equipment is not used and serviced in accordance with the instructions in this manual. If in doubt about a procedure, please contact Honeywell Analytics before proceeding.

1 System Description

The Dual Relay Module (DRM) is a single channel 4/20 mA analog input feed-thru device designed to provide a dual stage alarm with isolated relay outputs. An additional configuration on applications for termination at the DRM (non-feed through) is illustrated later in this manual. The two relay outputs can be used to activate local annunciators, warning strobes, PLC inputs, and other output-driven applications. The DRM is powered by control panels or PLC's that provide a +24 VDC source. The DRM is wired in series with the gas sensor, feeding the 4/20 mA signal back to the control panel or PLC that supplies a required load. Up to three modules can be wired in series for added relay outputs and alarm trip level flexibility. The DRM is equipped with dual alarm trip levels that are selectable between 33/100% and 50/100% (full-scale 20 mA) via a two position selector switch. The DRM has three internal status LED's to indicate Power On, First Alarm activation, and Second Alarm activation.

System Specifications

Power Supply Requirements: +18 to +26 VDC

Power Supply Current: 120 mA Max

Operating temperature: -10° F to +120° F

Humidity Conditions: 0% to 95% RH non-condensing

Relay Contacts: Isolated 5A @ 125 VAC / 100 VDC

Set point Adjustment: 33%/100% full-scale (20 mA) and 50%/100% full-scale (20 mA)

Built-in hysteresis: 2-second time delay for both On/Off transitions

Dimensions: 8.5" high x 8.5" wide x 2.5" deep

LED Status Indicators (Internal): Power (green), Low Alarm (yellow), High Alarm (red)

Connectors: Screw terminal type 22-gauge to 18-gauge stranded copper

Maximum distance from controller: 1000 feet

Figure 1: Mounting dimensions for the DRM

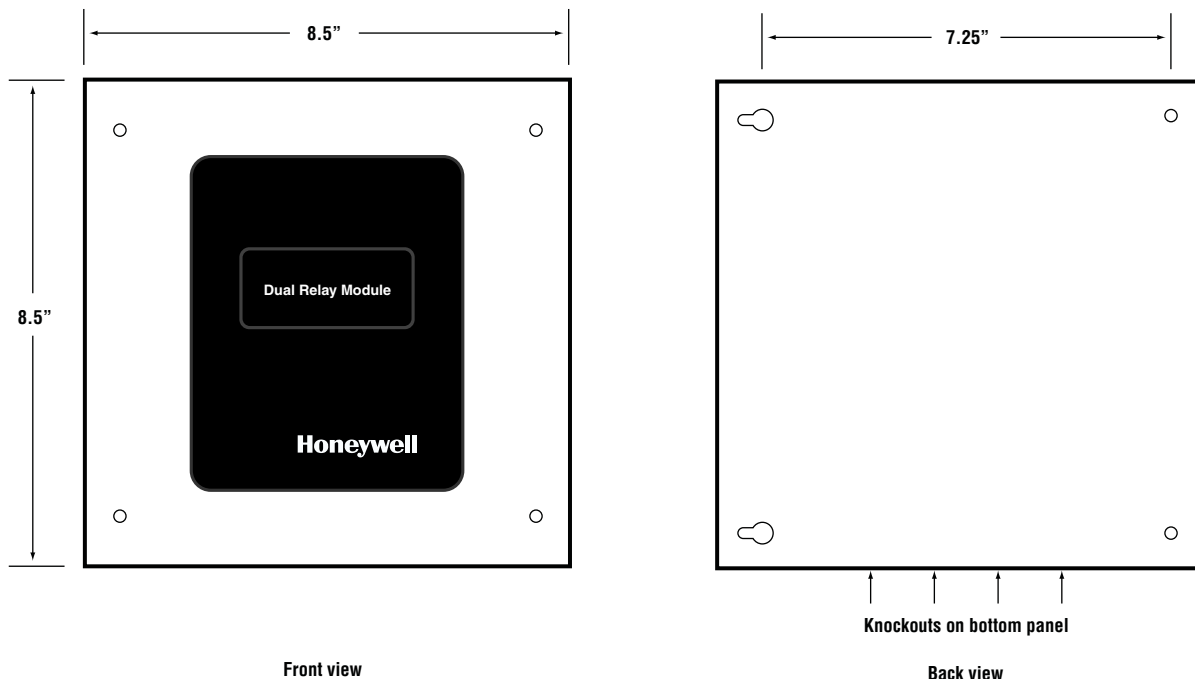

2 Installation

Wiring Diagram and Procedure for Feed-through Applications

In this configuration the control panel connector is provided +24 VDC, power ground, the shield, and a means for the 4/20 mA signal load that resides within the panel or PLC. This load should be purely resistive between 50 Ohms and 400 Ohms. Power to the sensor is fed from this connector. Signal from the sensor is fed to the Control Panel connector. The grounds and shield are a feed through and bridged between the Sensor and Control Panel connectors. Each relay output is isolated with a common “C”, normally open “NO” and normally closed “NC” connector for wiring to external equipment.

 **Note:** Be sure to follow the recommendations relating to the contact ratings before hooking up external devices to the relay contacts.

Figure 2: Feed-through connections



2 Installation continued

Wiring Diagram and Procedure for Terminated or Non-feed through Applications:

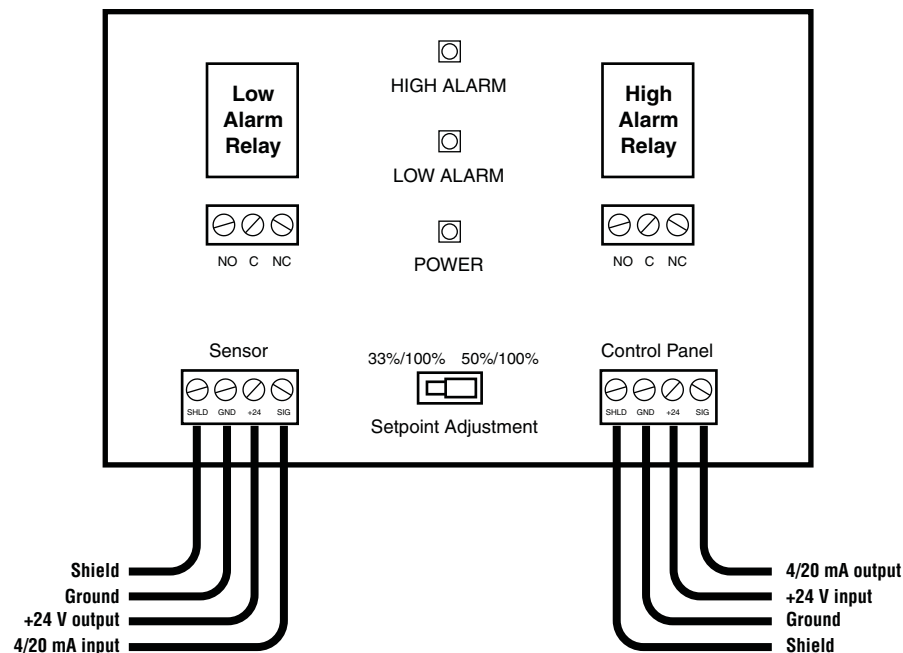
In this configuration the Control Panel connector is provided +24 VDC, power ground, and a resistor (see Figure 3, Note 1) connected to the sig. terminal and GND terminal. This resistor should be between 50 Ohms and 400 Ohms. This resistor provides the mA load that would normally exist in the control panel or PLC feed through applications. The shield terminal is not connected. Power to the sensor is fed from the Control Panel connector. Signal from the sensor is fed from the Sensor side to the Control Panel connector and through the resistor to ground. The ground is a feed through and bridged between the Sensor and Control Panel connectors. Each relay output is isolated with a common "C", normally open "NO" and normally closed "NC" connector for wiring to external equipment.

 **Note: Be sure to follow the recommendations relating to the contact ratings before hooking up external devices to the relay contacts.**

Figure 3: Non-Feed-through connections



3 Operation

When connected properly, the module will respond to a low mA threshold and a high mA threshold. The low mA threshold activating the low alarm relay and the a high mA threshold activating the high alarm relay. The low alarm threshold has two set points configured by the Set point Adjustment selector switch. The low alarm relay trip point can be set by this switch to trip at 33% of 20 mA (9.28 mA) or 50% of 20 mA (12 mA) on the signal input mA loop. One must add the offset of 4 mA to the active operating range of 16 mA to determine the actual current output for each respective trip level. The high alarm relay trip point is fixed at 20 mA.

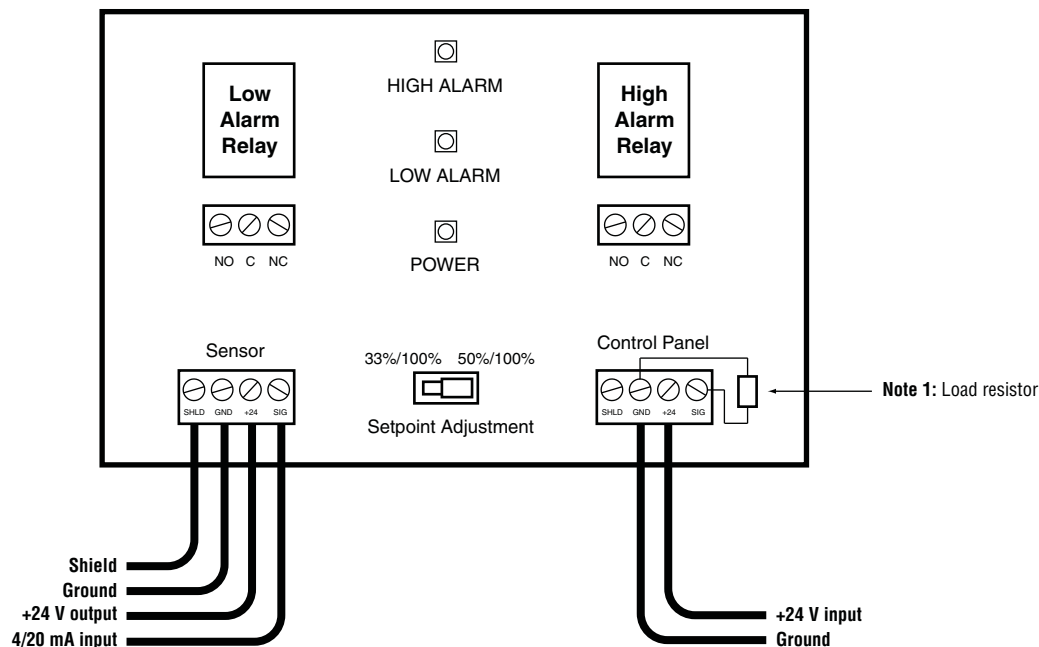
When the trip threshold current is reached, the module has a built in hysteresis for the on trip and off trip. This hysteresis time is 2 seconds. Therefore, a delay of 2 seconds will exist for all relay actuations to ensure stable operation in noisy environments.

When the unit is properly powered, a green LED will indicate power. When the low alarm threshold is reached, a Yellow LED labeled "LOW ALARM" will indicate low alarm activation. When the high alarm threshold is reached, a Red LED labeled "HIGH ALARM" will indicate High alarm activation.

4 Limited Warranty

1. Limited Warranty

Honeywell Analytics, Inc. warrants to the original purchaser and/or ultimate customer ("Purchaser") of Manning products ("Product") that if any part thereof proves to be defective in material or workmanship within eighteen (18) months of the date of shipment by Honeywell Analytics or twelve (12) months from the date of first use by the purchaser, whichever comes first, such defective part will be repaired or replaced, free of charge, at Honeywell Analytics' discretion if shipped prepaid to Honeywell Analytics at 405 Barclay Blvd., Lincolnshire, IL 60069, in a package equal to or in the original container. The Product will be returned freight prepaid and repaired or replaced if it is determined by Honeywell Analytics that the part failed due to defective materials or workmanship. The repair or replacement of any such defective part shall be Honeywell Analytics' sole and exclusive responsibility and liability under this limited warranty.

2. Exclusions

- A. If gas sensors are part of the Product, the gas sensor is covered by a twelve (12) month limited warranty of the manufacturer.
- B. If gas sensors are covered by this limited warranty, the gas sensor is subject to inspection by Honeywell Analytics for extended exposure to excessive gas concentrations if a claim by the Purchaser is made under this limited warranty. Should such inspection indicate that the gas sensor has been expended rather than failed prematurely, this limited warranty shall not apply to the Product.
- C. This limited warranty does not cover consumable items, such as batteries, or items subject to wear or periodic replacement, including lamps, fuses, valves, vanes, sensor elements, cartridges, or filter elements.

3. Warranty Limitation and Exclusion

Honeywell Analytics will have no further obligation under this limited warranty. All warranty obligations of Honeywell Analytics are extinguishable if the Product has been subject to abuse, misuse, negligence, or accident or if the Purchaser fails to perform any of the duties set forth in this limited warranty or if the Product has not been operated in accordance with instructions, or if the Product serial number has been removed or altered.

4. Disclaimer of Unstated Warranties

THE WARRANTY PRINTED ABOVE IS THE ONLY WARRANTY APPLICABLE TO THIS PURCHASE. ALL OTHER WARRANTIES, EXPRESS OR IMPLIED, INCLUDING, BUT NOT LIMITED TO, THE IMPLIED WARRANTIES OF MERCHANTABILITY OR FITNESS FOR A PARTICULAR PURPOSE ARE HEREBY DISCLAIMED.

5. Limitation of Liability

IT IS UNDERSTOOD AND AGREED THAT HONEYWELL ANALYTIC'S LIABILITY, WHETHER IN CONTRACT, IN TORT, UNDER ANY WARRANTY, IN NEGLIGENCE OR OTHERWISE SHALL NOT EXCEED THE AMOUNT OF THE PURCHASE PRICE PAID BY THE PURCHASER FOR THE PRODUCT AND UNDER NO CIRCUMSTANCES SHALL HONEYWELL ANALYTICS BE LIABLE FOR SPECIAL, INDIRECT, OR CONSEQUENTIAL DAMAGES. THE PRICE STATED FOR THE PRODUCT IS A CONSIDERATION LIMITING HONEYWELL ANALYTICS' LIABILITY. NO ACTION, REGARDLESS OF FORM, ARISING OUT OF THE TRANSACTIONS UNDER THIS WARRANTY MAY BE BROUGHT BY THE PURCHASER MORE THAN ONE YEAR AFTER THE CAUSE OF ACTIONS HAS OCCURRED.